

METRO CURVE

STREET LIGHT



The Metro Curve Series Street Light offers incorporates a sleek, modern design with cost effective, intelligent LED lighting solution. The Metro Curve features an adjustable knuckle bracket, anti-corrosion properties, and an IP66 waterproof cover.

With an optional DALI or 0-10V dimming control, daylight sensor, and smart control NEMA 7pin Socket, the Metro Curve Street Light is an energy efficient and sustainable lighting solution.

An ideal solar street light option for streets, car parks, public area, and industrial sites.

EASY ACCESS FOR MAINTENANCE



- ✓ **Sleek and Smooth Design Diminishes Dust Accumulation**
- ✓ **Adjustable Knuckle Bracket Included**
- ✓ **Water Proof Cover and Anti-Corrosion Material**
- ✓ **Intelligent Dali, 0-10v Dimming Controls**
- ✓ **Timer Compatible for Greater Energy Savings**
- ✓ **Smart City Enabled Nema Socket Options**
- ✓ **Tool-Free Replacement, Quick and Easy Maintenance**



LEARN MORE

SPECIFICATIONS

METRO CURVE STREET LIGHT

Model	ETG-06MC001	ETG-06MC002	ETG-06MC003	ETG-06MC004
Power (Wattage)	30	50	70	90
Lumens (lm)	4,200	7,000	9,800	12,600
Weight (kg)	5.9±0.3	5.9±0.3	5.9±0.3	7.9±0.3
Dimensions (mm)	649 × 272 × 179 mm	649 × 272 × 179 mm	649 × 272 × 179 mm	887x378x196 mm

Model	ETG-06MC006	ETG-06MC007	ETG-06MC008
Power (Wattage)	150	180	240
Lumens (lm)	19,500	25,200	34,800
Weight (kg)	7.9±0.3	10.0±0.3	10.0±0.3
Dimensions (mm)	649 × 272 × 179 mm	649 × 272 × 179 mm	649 × 272 × 179 mm

Luminous Efficacy	140lm/W
CCT(K)	4000K (Optional 3000K-5000K)
LED Chips	Nichia Chip (Japan)
Input Voltage (AC)	100-240 V AC 50/60Hz
Optional DC Input Voltage (DC)	24-48 V DC (Solar Compatible)
Surge Protection	10kV / 12kV
Operating Temp	-30°C – 50°C
PF	>0.90 / >0.92
IP/IK Rating	IP66 / IK08
CRI	>70 (>80 Optional)
Protection Class	Class I
Housing	ALU Alloy + PC Inner Lens + Tempered Glass (Outer)
Optional Controls	DALI / Photocell / Timer Control
Optional Accessories	Photocell Controller / Nema Socket
Lifespan	>70,000 (Ta=30°C@L70)
Warranty	7 Years



Accessories

Swivel Pole

7.5 Metre Standard Pole

1400 x 1400 x 500mm Concrete Base

Spigot/ Mount Options

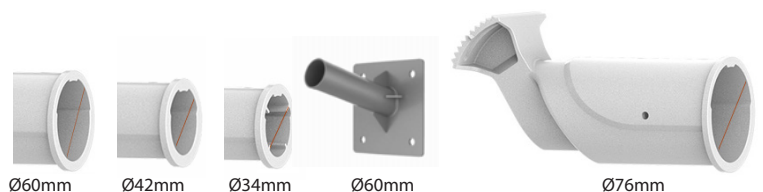

DIMENSIONS

METRO CURVE STREET LIGHT

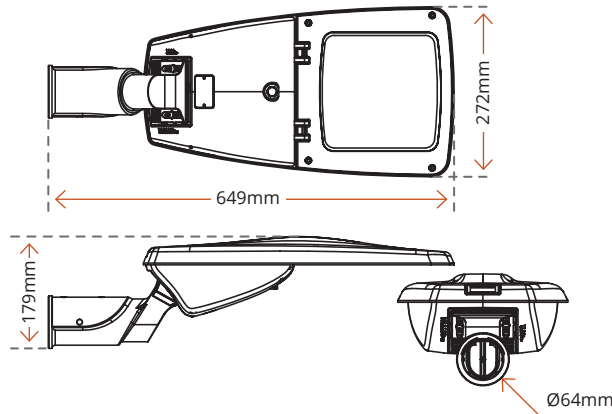

ETG-06MC001 | ETG-06MC002 | ETG-06MC003

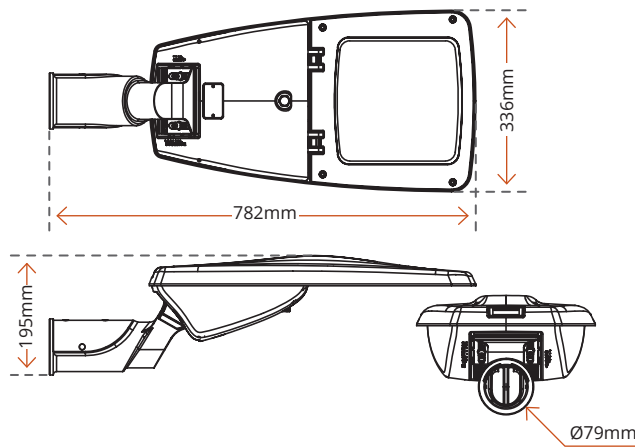

ETG-06MC004 | ETG-06MC006

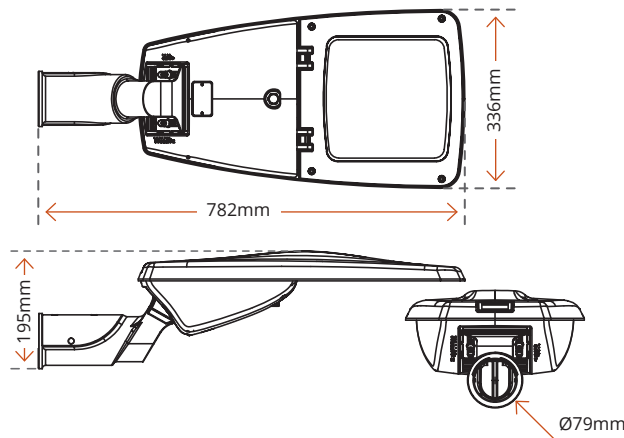

ETG-06MC007 | ETG-06MC008



1300 410 485 | sales@etms.com.au | www.etms.com.au

