

SOLAR PRO FLEX

STREET LIGHT



IP66
RATING
FOR DUST &
WATER
RESISTANCE

The Solar Pro Flex Street Light offers tough and powerful solar lighting with an adjustable solar panel for optimal coverage and positioning. It features smart controls including a microwave sensor, timer, and dimming options, enhancing efficiency and lifespan. It's sleek design, IP66 & IK08 ratings, and durable materials gives the Solar Pro Flex solar street light protection against harsh weather conditions. Because of The Solar Pro Flex's adjustability, it is the best choice in areas such as streets, pathways and car parks where full solar panel positioning is needed.

ADJUSTABLE SOLAR PANEL FOR OPTIMAL POSITIONING

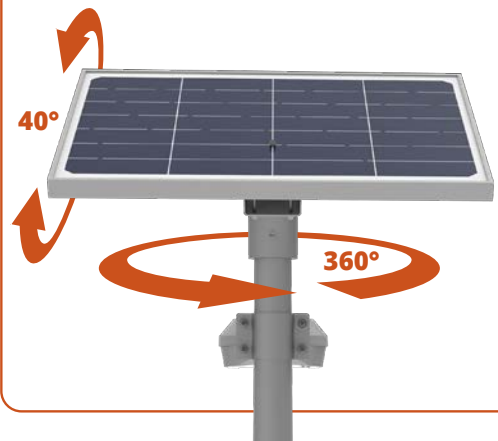

- ✓ **2-3 Night Lighting, Even Through Rainy Or Cloudy Weather**
- ✓ **Removeable Lifepo4 Lithium Battery**
- ✓ **Rounded Design For Better Wind Resistance**
- ✓ **Built-In Smart Controls Such As Microwave Sensor And Timer Dimming Increase Efficiency**
- ✓ **Highly Efficient 200 Lumen Per Watt Output**
- ✓ **The Lamp Body Of The Street Light Opens Easily For Maintenance**
- ✓ **Mountable On Break-Back Or Fixed Poles At Various Heights**



LEARN MORE

SPECIFICATIONS

STREET LIGHT

Model	ETG-11FL074
Power (W)	60 DC
Lumen (Lm)	12,000
Luminous Efficacy (Lm/W)	200
Battery	LifePo4 lithium battery
Battery Capacity (Wh)	230.4
Solar Panel (W)	90
Solar Panel Dimension (Mm)	820 X 670 x 67
Luminaire Dimension (Mm)	502 X 216 x 106
Solar Panel Weight (Kg)	7.5
Luminaire Weight (Kg)	5.2
Ip Rating	IP66
Charging Time (H)	3
Solar Charging Controller	MPPT
Lighting	Operates at 30% brightness. Once triggered, it brightens to 100% and remains at 100% until no further motion is detected.
Cct	4000K
Cri	Ra70 (optional: Ra80)
Beam Angle	R22802
Smart Control	Microwave sensor
Operating Temperature	0°C ~ 50°C
Material	Aluminium alloy + polycarbonate optical lens
Body Colour	Silver
Mounting	Side entry
Led Lifespan	40,000 82,000hrs (I80) 131,000hrs (I70)
Warranty	3 years

DIMENSIONS

STREET LIGHT

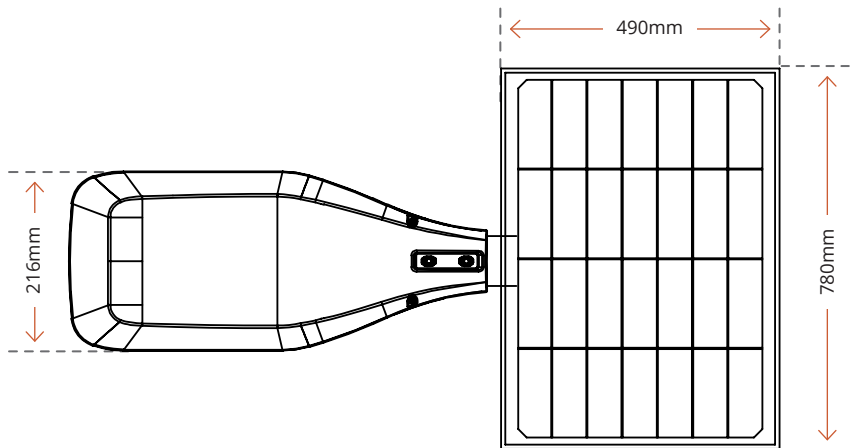
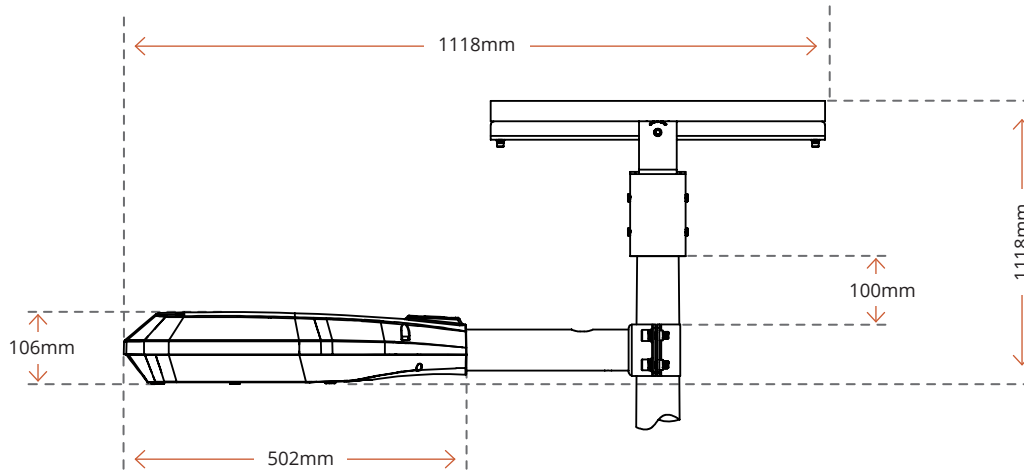



1300 410 485 | sales@etms.com.au | www.etms.com.au

