

# ECO WALL PACK

## WALL LIGHT

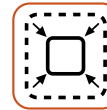

Add ambience and safety to the exterior of any building or ledge with the Eco Wall Light. It features an angled PC lens to direct the light both where it is needed. Perfect for near stairs or to illuminate objects to make an area safer for pedestrians or as subtle way finding through parks and gardens.

### **STREAMLINED COMPACT DESIGN**



- ✓ **Easy Installation Wall Lighting**
- ✓ **IK07 Impact Resistant**
- ✓ **IP65 Weather Protection**
- ✓ **Energy Efficient 110 Lm/W Output**
- ✓ **Compact, Modern Architectural Lighting Solution**
- ✓ **Angled Lighting Area Provides Greater Coverage for Night Safety**



**LEARN MORE**

# SPECIFICATIONS

## ECO WALL PACK LIGHT

Code	ETG-07EW003	ETG-07EW004
Power (W)	60	120
Lumen (lm)	6,600	13,200
Weight (kg)	2.3	3.7
Dimension (mm)	385 x 260 x 230	490 x 260 x 230
Driver	Philips	
Input Voltage (V)	AC 100-277V - 50/60Hz	
Luminous efficacy (lm/W)	110	
PF	≥0.90	
CCT	4000K (Optional 3000K, 5000K, 5700K)	
CRI	Ra70 (Optional 80)	
Mounting	Wall Mount	
Operating Temperature	-30°C ~ +50°C (10%~90%RH)	
LED Type	Lumileds	
IP Rating	IP65	
IK Rating	IK07	
Body + Lens	Aluminum Alloy & PC Lens	
Colour	Bronze	
Mounting	Wall Mount	
Life Span (Hr)	>50,000	
Certifications	CE, Rohs,SAA	

# DIMENSIONS

## ECO WALL PACK LIGHT

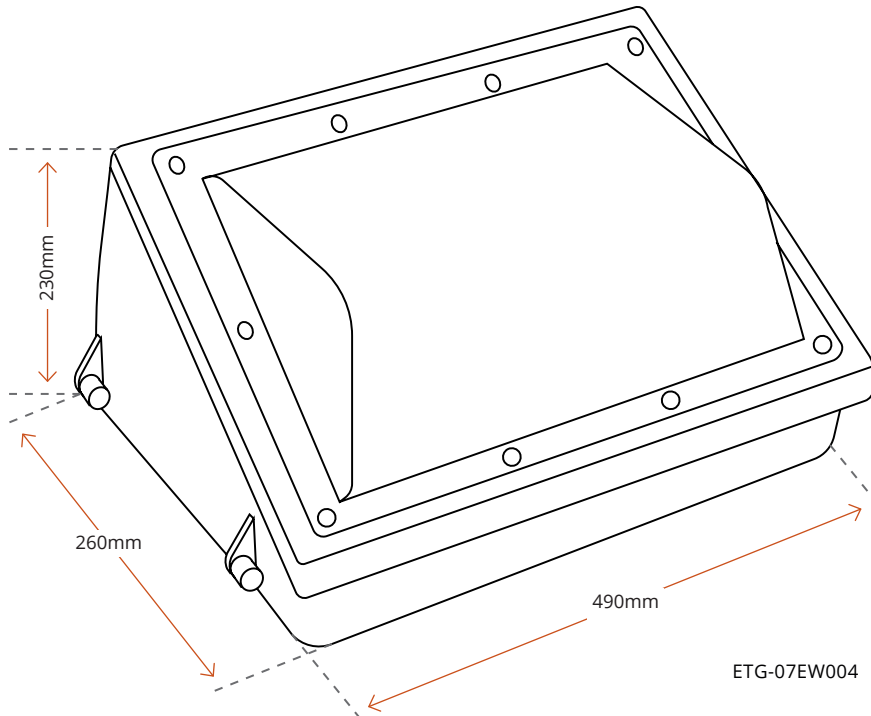
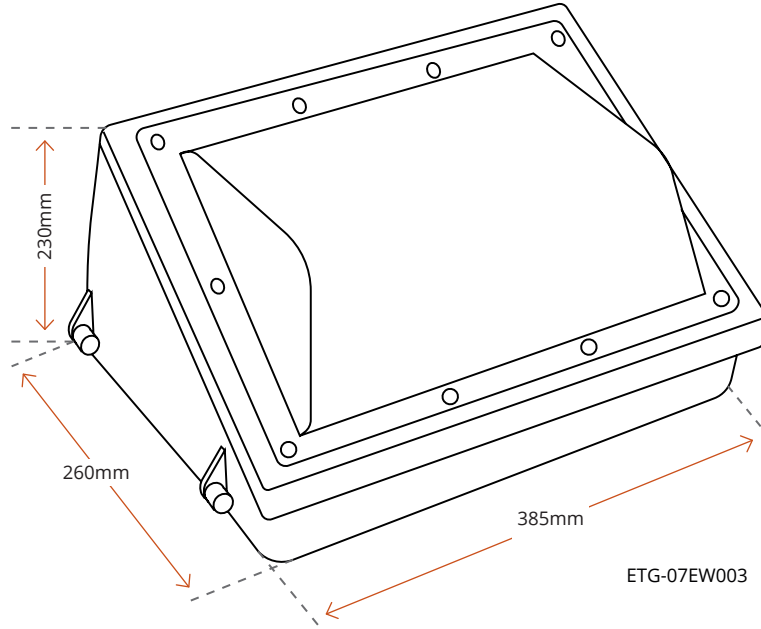



1300 410 485 | [sales@etms.com.au](mailto:sales@etms.com.au) | [www.etms.com.au](http://www.etms.com.au)

