

BLITZ

HIGHBAY LIGHT



IP65
RATING
FOR DUST &
WATER
RESISTANCE

IK08
IK RATING
FOR IMPACT
RESISTANCE



5
YEAR WARRANTY
*ON LUMINAIRE

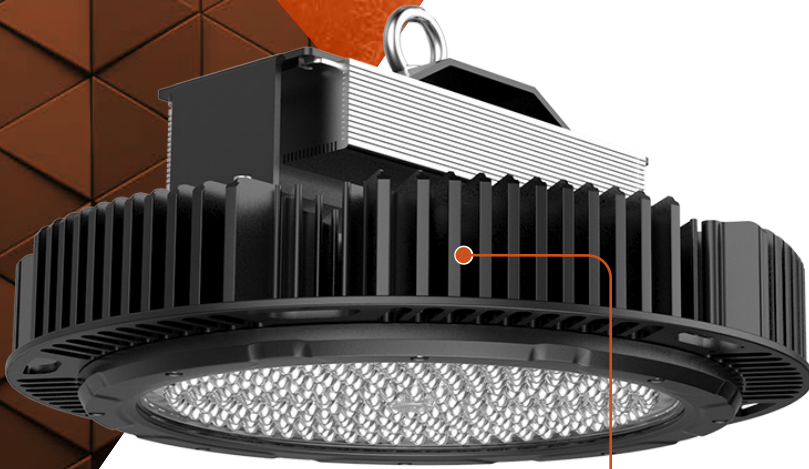

The Blitz High Bay is a premium energy efficient LED high bay lighting solution that offers bright, powerful illumination with enhanced heat dissipation and dimmable options. With intelligent controls, such as Zigbee, daylight sensors, PIR sensors, and microwave motion sensors, this high bay lighting system is designed for durability and sustainability. Ideal for industrial, warehouse, indoor sporting facilities and shed lighting applications, the Blitz Series UFO High Bay ensures optimal visibility and efficiency in your workspace.

- ✓ **Brightest Highbay Option Available for High Ceiling Applications**
- ✓ **Cutting Edge LED Technology**
- ✓ **Wide Range of Optics Available, Including Narrow Beam**
- ✓ **Dimmable and Optional Intelligent Controls (Zigbee Controls, Daylight, Pir, Microwave Sensor)**
- ✓ **IP65 for Dust and Water Resistance, and IK08 for Impact Resistance**
- ✓ **5 Year Warranty**

GREAT HEAT DISSIPATION

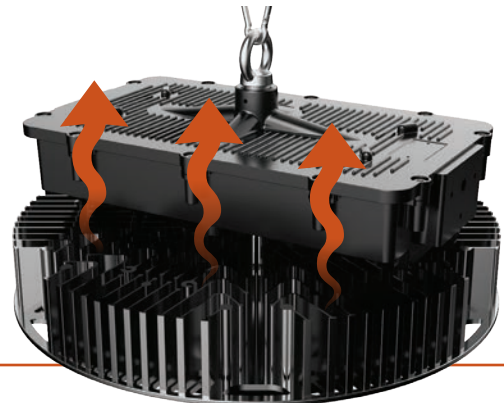

LEARN MORE

SPECIFICATIONS

BLITZ HIGHBAY LIGHT

Code	ETG-08BS016	ETG-08BS017
Power W	450	600
Lumen (lm)	72,000	96,000
Beam Angle	90° (450W)	60° (600W)
Luminous Efficacy	160lm/W	
CCT (K)	5000K	
Input Surge Protection	6kV line-line, 10kV line-earth	
Input Voltage	100-240 VAC 50/60Hz	
LED Chip	Lumileds	
CRI (Ra)	>70	
Beam Angle	90°	
PF	0.92	
Dimmable	Yes	
System Power Consumption	450±13W	
Operating Temp	-30°C to +50°C	
IP Rating	IP65	
IK Rating	IK08	
Protection Class	Class I	
Body	Aluminium alloy + PC Lens	
Lifespan	50,000Hrs	
Net Weight	11.2 ± 0.3Kg	
Dimension (mm)	Ø454 × 263	
Mounting Options	Eye hook, Bolt Hanging / Ceiling Mount	
Warranty	5 Years	
Intelligent Controls	ZigBee Control / Daylight / Microwave / PIR Sensor	

DIMENSIONS

BLITZ HIGHBAY LIGHT

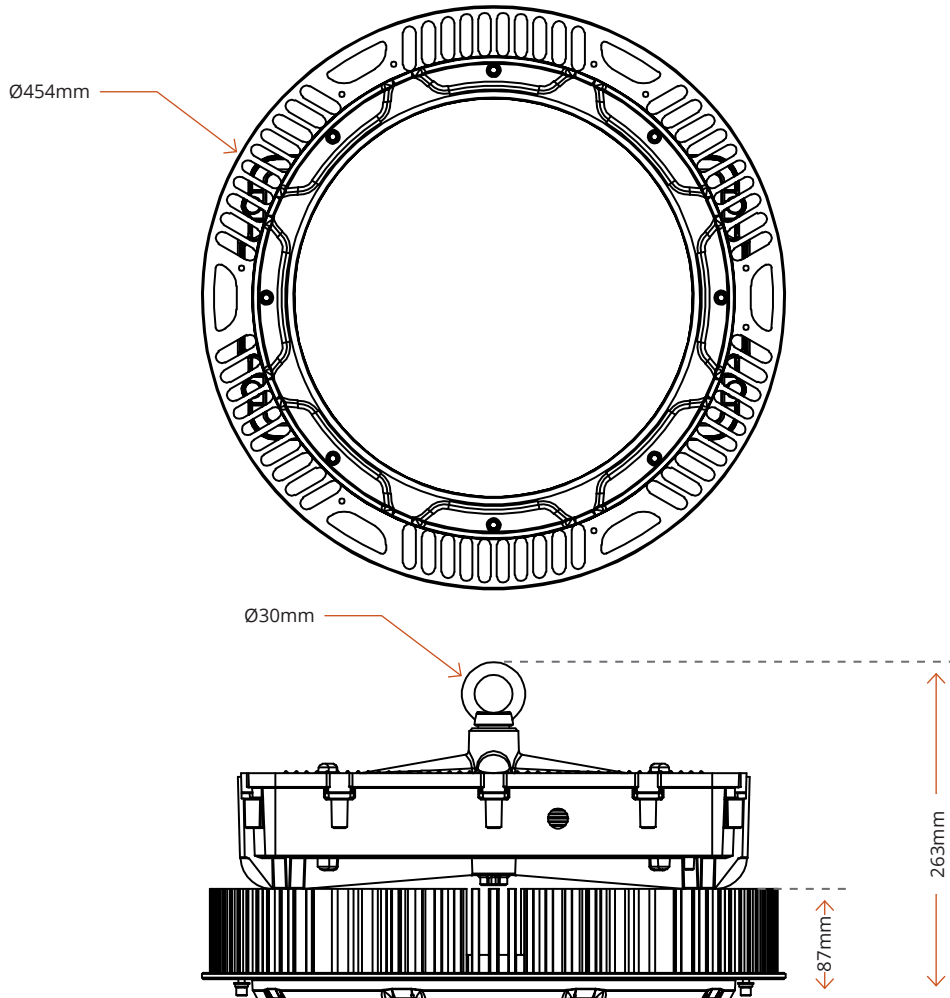



1300 410 485 | sales@etms.com.au | www.etms.com.au

