

## PATHWAY CONVEYOR LIGHT



Designed for high-vibration and impact prone areas such as conveyor belts, this versatile light also offers emergency battery backup and solar-powered options. Available in Amber, this light will not impact sensitive wildlife areas, and the Green-chip option is ideal for site first-aid stations. Not just a conveyor light, The Kestrel is a great choice for conveyors, walkways, tunnels, roadways, industrial settings, mining operations, and environmentally sensitive areas. It provides an impressive brightness of over 40 Lux on the ground surface when placed 14 meters apart on 3-meter high poles, surpassing the standard needed for most conveyor systems. It also adheres to the AS/ NZS ISO 9001:2015 quality management standards, ensuring reliable performance.

### AMBER & GREEN EYEWASH OPTIONS AVAILABLE



- ✓ Designed For High Vibration and High Impact Areas (Ik08)
- ✓ More Than 40 Lux Brightness on the Surface Using 3m Tall, 14m Spaced Poles
- ✓ Solid-State Integral Emergency Option With Intelligent Controls
- ✓ IP66 Water & Dust Proof
- ✓ Better Heat Dissipation, Flicker-Free and Life-Long Led
- ✓ Smart City Enabled Nema Socket Options
- ✓ Tool-Free Replacement, Quick and Easy Maintenance



**LEARN MORE**

# SPECIFICATIONS

## KESTREL PATHWAY CONVEYOR LIGHT

Model	ETG-05KC002	ETG-05EK004	ETG-05EK005
Type	Standard	Emergency	Green Eyewash - Emergency
Power (Wattage)	70	70	70
Lumens (lm)	9,800	9,800	-
CCT	4000K		
Input	AC		
Battery	Built in		
Model	ETG-05DC006	ETG-05DC007	
Type	Solar Compatible	Green Eyewash - Solar Compatible	
Power (Wattage)	70		
Lumens (lm)	9,800		
Input	DC		
Luminous Efficacy	140lm/W		
Ac Input	110 - 265 VAC		
Dc Input	9 -32 VDC		
Led Chip	Nichia   Osram : green		
Battery	4W 3H battery (EM models)		
CCT	4000K [amber / 5000K]		
Operating Temp	-30°C TO +50°C		
Input Surge Protection	20KV SPD		
PF	>0.95		
Intelligent Controls (Optional)	DALI control/ photocell/ timer control		
Beam Angle	140°		
Mounting Option (mm)	Horizontal spigot mount Ø32-35 & 40-44		
CRI	>70 (optional >80)		
IP/IK Rating	IP66 / IK08		
Cable Ø / Gland / Cable	2.5 mm <sup>2</sup> - 3 Core cable / M20 / 3m length		
Body	ALU alloy + PC lens / black		
Optional Accessories	Photocell controller / 7 pin NEMA socket		
Weight (kg)	4.7 (Standard range) / 6.2 (Emergency range)		
Lifespan	>50,000 (70% brightness)		
Warranty	5 Years (1 year battery)		

# DIMENSIONS

## KESTREL PATHWAY CONVEYOR LIGHT

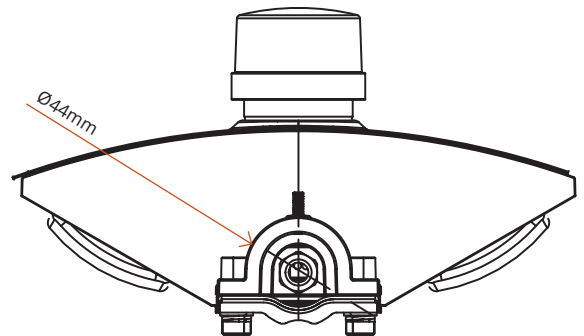
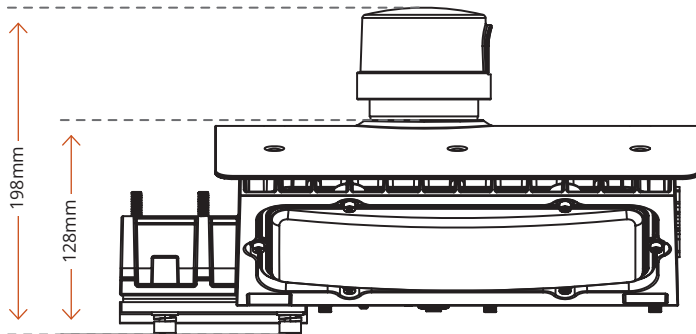
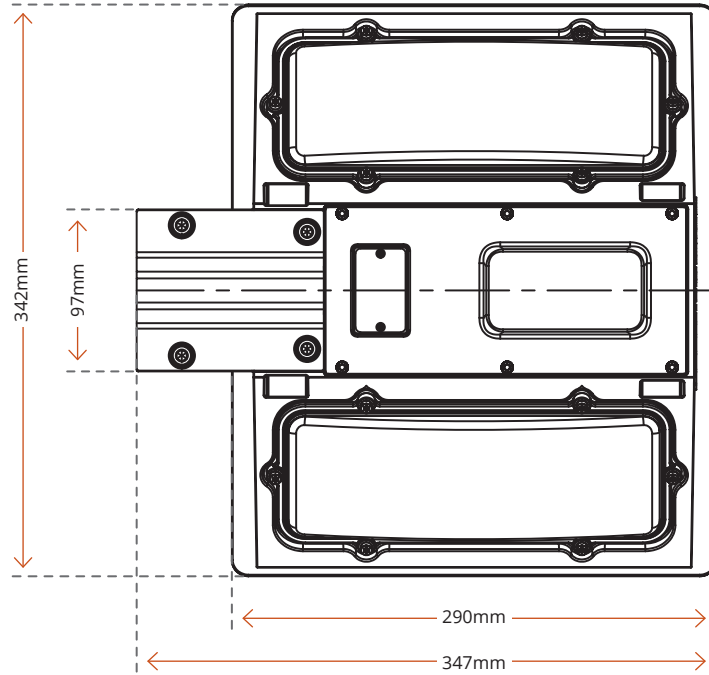



1300 410 485 | [sales@etms.com.au](mailto:sales@etms.com.au) | [www.etms.com.au](http://www.etms.com.au)

