

MAXI G3 SOLAR

STREET LIGHT TOWER



Maxi G3 Solar Street Light Tower is a new generation powerful, reliable area street light up to 12,000 lumens in singular model and 14,000 lumens in twin model. Whisper-quiet operation, zero carbon emissions and renewable energy powered for maximum environmental benefits. Made in Australia and designed to withstand Australia's harsh remote conditions.

- ✓ **Vandal-Resistant, Secure Control Box**
- ✓ **Powerful, Long-Lasting Lithium Battery Technology With Intelligent Features**
- ✓ **Easy Access And Ergonomic Control Box For Maintenance**
- ✓ **Concrete Block Mounted With Region D Option Available**
- ✓ **Plug & Play Pre-Programmed Intelligent Controller Automatic On/Off**
- ✓ **Heat Dissipation Optimized Design, With Cooling Vents And Fan**
- ✓ **Premium Winch And Counterweight Construction For Easy Pole Lowering**

TWIN OPTION AVAILABLE



LEARN MORE

SPECIFICATIONS

MAXI G3 SOLAR STREET LIGHT TOWER

Code	ETG-01TM016	ETG-01TM017	ETG-01TM019
Power (W)	50	90	100
Lumen(lm)	7,000 lm	12,600 lm	7000 lm x 2
Battery Storage (LiFePO4)	150 Ah (24V)	200 Ah (24V)	200 Ah (24V)
Optional Upgrade	Cyclone rated 1m3 -1.5m3 Concrete block		
Input Voltage (Luminaire)	24V DC		
LED Chip	Nichia - Japan		
IP Rating	IP66 (Luminaire) IP68 (PV Panel)		
Light & Panel Rotate	360° (Adjustable)		
Battery	LiFePO4 - Lithium battery		
Battery Box	Lockable, vandal resistant & vent fan		
Solar PV Power	400W		
Luminaire Body	Aluminium alloy + PC Lens		
Pole	Galvanised finished		
Pole Type	Break back - manual winch tilt		
BASE OPTIONS	DESCRIPTION		
Concrete Base	1600 x 1600 x 600 - 4 Tonne		

METRO CURVE STREET LIGHT

Sleek, modern design and a robust LED street lighting solution and easy maintenance. 7 Year Warranty.



Code	ETG-21MD042	ETG-21MD042
POWER (W)	50W	90W
Lumens (lm)	7000lm	12,600lm
Luminous Efficacy (lm/W)	140lm/W	
Weight (Kg)	10.0±0.3	
Dimension (mm)	887 x 378 x 196	
Voltage	12-24V DC	
Input Surge Protection	6kV line-in, 10kV line-earth	
Operating Temp	-30°C ~ 50°C	

DIMENSIONS

MAXI G3 SOLAR STREET LIGHT TOWER

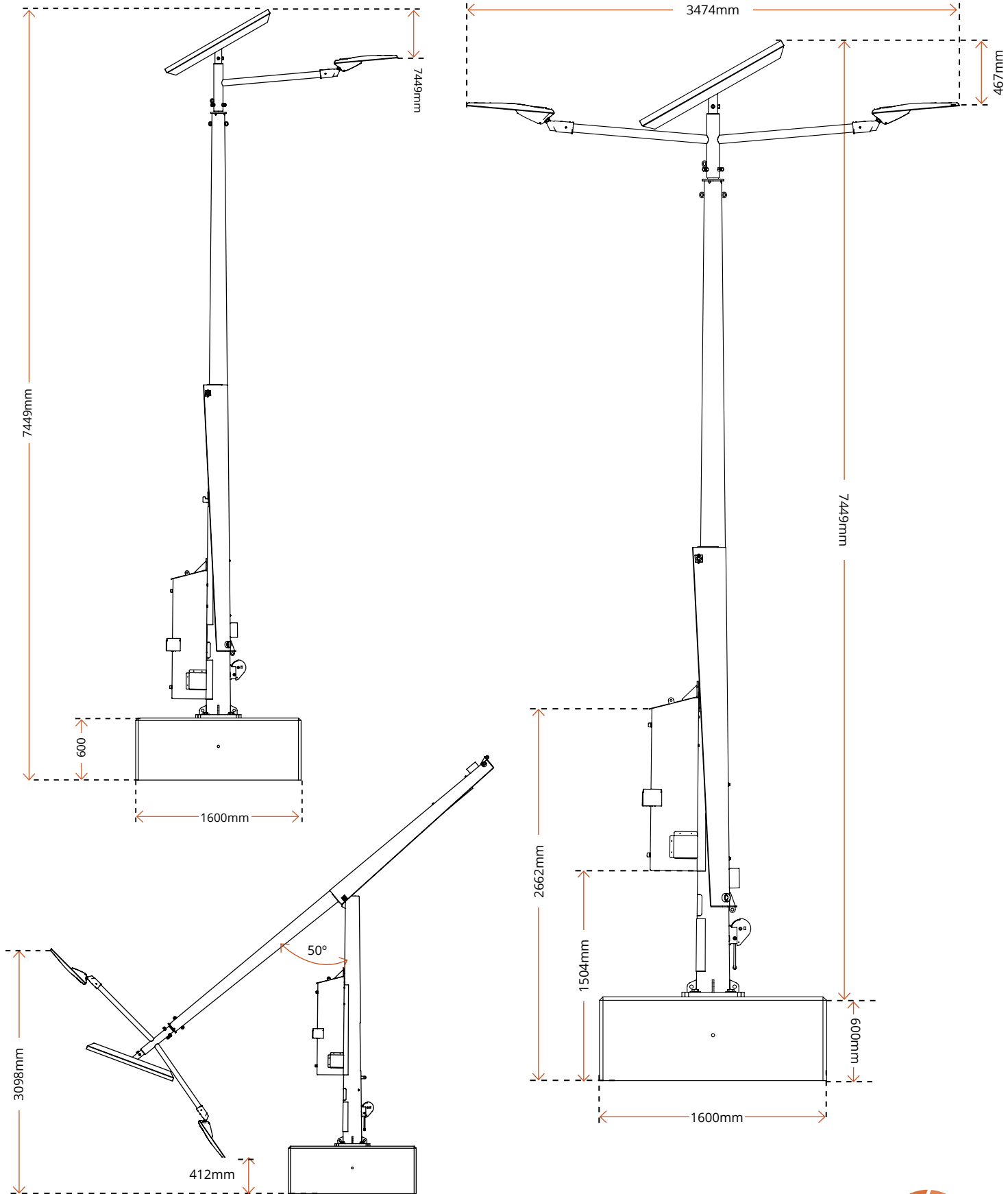



1300 410 485 | sales@etms.com.au | www.etms.com.au

