

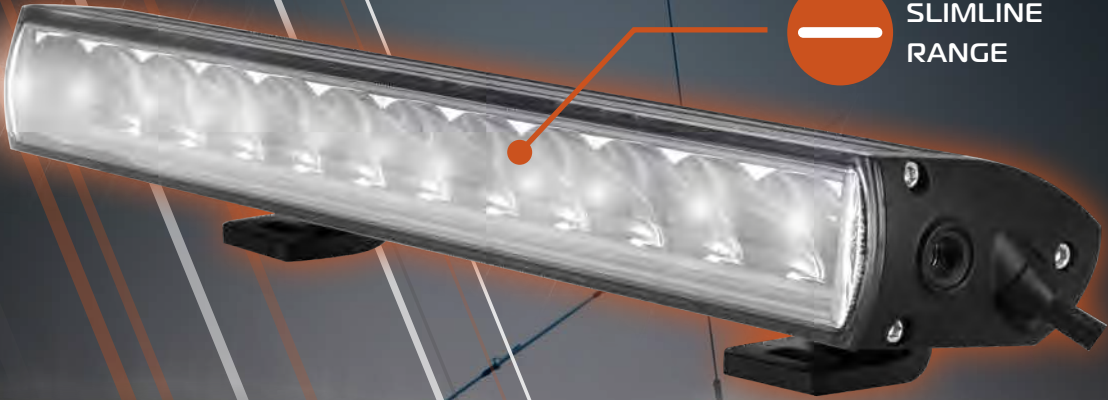

SLIMLINE RANGE



DUAL LINE RANGE



# SABRE SERIES

ALL TERRAIN LIGHT BARS

CURVED RANGE



SIDE REFLECTIVE OPTICS

UV & SHOCK RESISTANT

ADVANCED COOLING SYSTEM  
BREATHING FILTERS



SIDE & REAR FINS EFFICIENTLY  
DISPERSE HEAT, KEEPING THE LIGHTS  
COOL & WORKING OPTIMALLY.

# SABRE SERIES

SABRE SLIMLINE LIGHT BAR RANGE

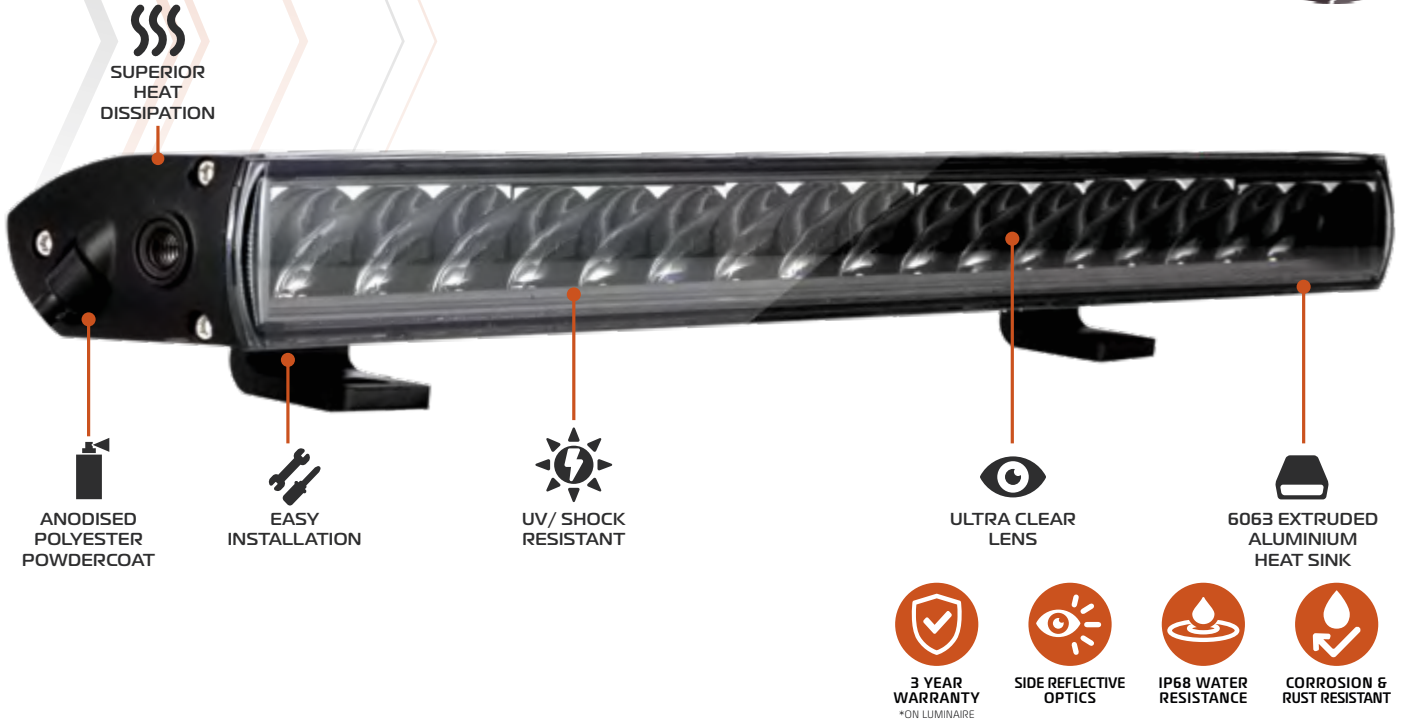

**A** EVSS90LED (20.2")

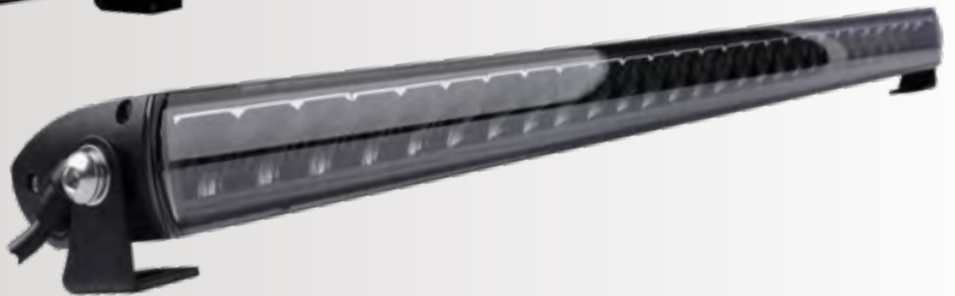

**B** EVSS135LED (29.8")

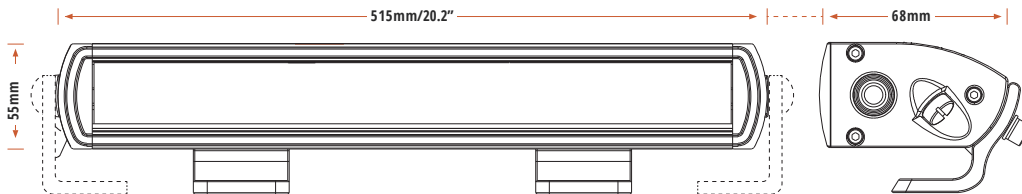

EVSS90LED (20.2")

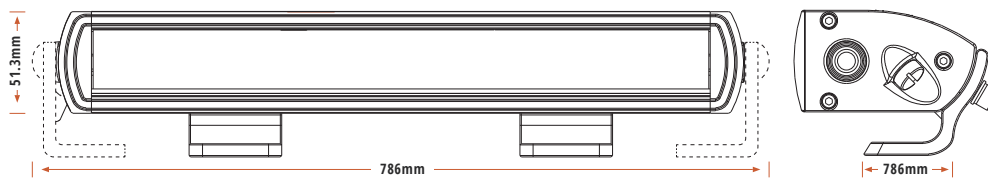

EVSS135LED (29.8")

\* SIZING WITH OPTIONAL SIDE BRACKET



# SABRE SERIES

SABRE SLIMLINE LIGHT BAR RANGE



EVSS90LED | 20.2"



EVSS135LED | 29.8"

**SPECIFICATIONS**

WATTAGE	90 WATT
LIGHT SOURCE	18 x 5W LG LEDS
LIGHT OUTPUT	8,100 LUMEN
VOLTAGE	9V-36V DC
OPERATING TEMP.	-40°C TO +60°C
IP RATING	IP68
CONNECTOR TYPE	DEUTSCH CONNECTOR
HOUSING	6063 EXTRUDED ALUMINUM HEAT-SINK
LENS CONSTRUCTION	POLYCARBONATE
BRACKET	STAINLESS STEEL
LIFESPAN	50,000 HOURS
NET WEIGHT	1.13 KG
MOUNTING SUITABLE	UPRIGHT SIDE & BACK OPTIONS
WARRANTY	3 YEARS

**SINGLE SLIMLINE 90W LIGHT BAR**

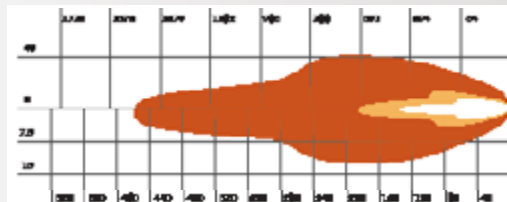

BEAM DRIVING SPOT  
 CODES EVSS90LED

**SINGLE SLIMLINE 135W LIGHT BAR**

WATTAGE	135 WATT
LIGHT SOURCE	27 x 5W LG LEDS
LIGHT OUTPUT	12,200 LUMEN
VOLTAGE	9V-36V DC
OPERATING TEMP.	-40°C TO +60°C
IP RATING	IP68
CONNECTOR TYPE	DEUTSCH CONNECTOR
HOUSING	6063 EXTRUDED ALUMINUM HEAT-SINK
LENS CONSTRUCTION	POLYCARBONATE
BRACKET	STAINLESS STEEL
LIFESPAN	50,000 HOURS
NET WEIGHT	1.88 KG
MOUNTING SUITABLE	UPRIGHT SIDE & BACK OPTIONS
WARRANTY	3 YEARS

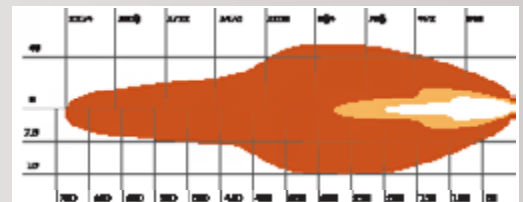

BEAM DRIVING SPOT  
 CODES EVSS135LED

# SABRE SERIES

SABRE DUAL LINE LIGHT BAR RANGE



**3 YEAR WARRANTY**  
\*ON LUMINAIRE



**SIDE REFLECTIVE OPTICS**



**IP68 WATER RESISTANCE**



**CORROSION & RUST RESISTANT**



**SUPER BRIGHT**



**SUPERIOR HEAT DISSIPATION**



**SIDE & BOTTOM BRACKET FITTINGS**



**EASY TILT ADJUST**



**EASY INSTALLATION**



**ANODISED POLYESTER POWDERCOAT**



**UV/ SHOCK RESISTANT**



**ULTRA CLEAR LENS**



**ALUMINIUM HOUSING**

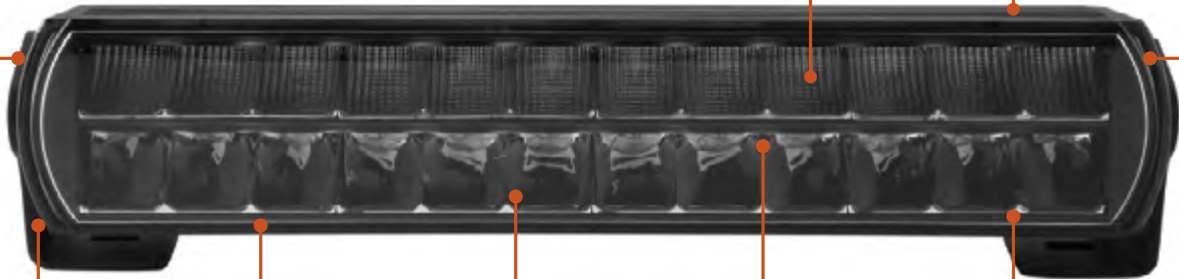

**A** EVSD120LED | 14.2"

**B** EVSD180LED | 20.6"

\* BACK BRACKET SIZING

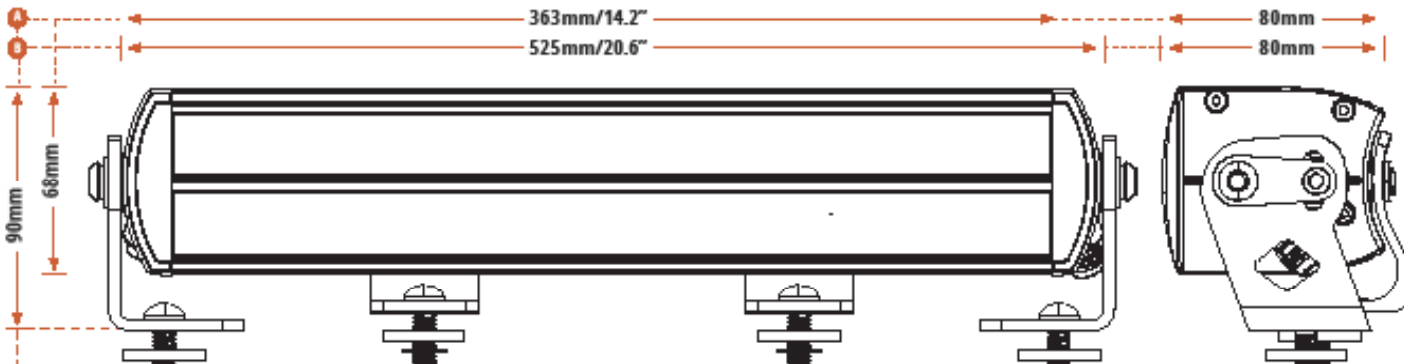

# SABRE SERIES

SABRE DUAL LINE LIGHT BAR RANGE



EVSD120LED | 14.2"



EVSD180LED | 20.6"

**SPECIFICATIONS**

<b>SPECIFICATIONS</b>	<b>WATTAGE</b>	120 WATT
	<b>LIGHT SOURCE</b>	24 x 5W LG LEDS
	<b>LIGHT OUTPUT</b>	10,900 LUMEN
	<b>VOLTAGE</b>	9V-36V DC
	<b>AMP DRAW</b>	6.9A/3.4A
	<b>OPERATING TEMP.</b>	-40°C TO +60°C
	<b>COLOUR TEMP.</b>	6000K
	<b>IP RATING</b>	IP68
	<b>CONNECTOR TYPE</b>	DEUTSCH CONNECTOR
	<b>HOUSING</b>	6063 EXTRUDED ALUMINUM HEAT-SINK
	<b>LENS CONSTRUCTION</b>	POLYCARBONATE
	<b>BRACKET</b>	STAINLESS STEEL
	<b>LIFESPAN</b>	50,000 HOURS
	<b>NET WEIGHT</b>	2.2 KG
	<b>MOUNTING SUITABLE</b>	SIDE AND BOTTOM OPTIONS
	<b>WARRANTY</b>	
<b>BEAM</b>	DRIVING SPOT	
<b>CODES</b>	EVSD120LED	

**DUAL LINE 120W LIGHT BAR**

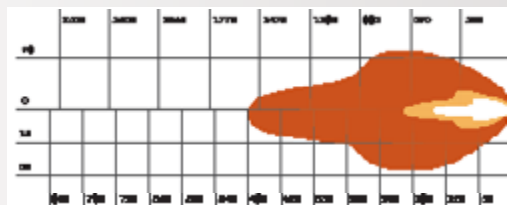

**DUAL LINE 180W LIGHT BAR**

<b>WATTAGE</b>	180 WATT
<b>LIGHT SOURCE</b>	36 x 5W LG LEDS
<b>LIGHT OUTPUT</b>	16,400 LUMEN
<b>VOLTAGE</b>	9V-36V DC
<b>AMP DRAW</b>	12.5A/5.9A
<b>OPERATING TEMP.</b>	-40°C TO +60°C
<b>COLOUR TEMP.</b>	6000K
<b>IP RATING</b>	IP68
<b>CONNECTOR TYPE</b>	DEUTSCH CONNECTOR
<b>HOUSING</b>	6063 EXTRUDED ALUMINUM HEAT-SINK
<b>LENS CONSTRUCTION</b>	POLYCARBONATE
<b>BRACKET</b>	STAINLESS STEEL
<b>LIFESPAN</b>	50,000 HOURS
<b>NET WEIGHT</b>	2.9 KG
<b>MOUNTING SUITABLE</b>	SIDE AND BOTTOM OPTIONS

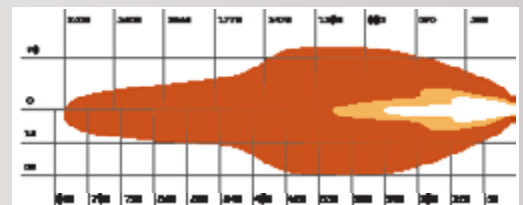

<b>BEAM</b>	DRIVING SPOT
<b>CODES</b>	EVSD180LED

# SABRE SERIES

SABRE CURVED LIGHT BAR RANGE



3 YEAR WARRANTY  
\*ON LUMINAIRE



SIDE REFLECTIVE OPTICS



IP68 WATER RESISTANCE



CORROSION & RUST RESISTANT



EASY TILT ADJUST

40% BRIGHTER

UV/ SHOCK RESISTANT

SUPER BRIGHT

EASY INSTALLATION

CURVED DESIGN FOR A STREAMLINED FINISH

ULTRA CLEAR LEXAN PC FRONT COVER

EXTRUDED ALUMINIUM FOR SUPERIOR HEAT-SINK

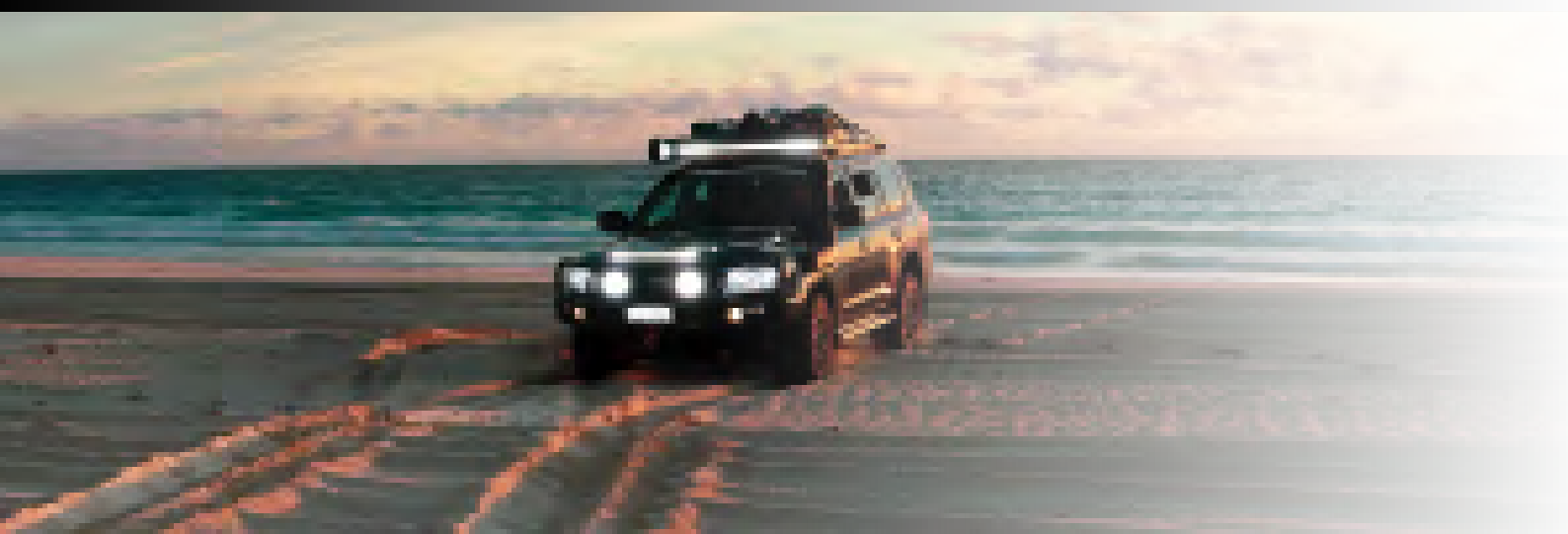

**A** EVSC100LED | 20.6"

**B** EVSC220LED | 43.3"

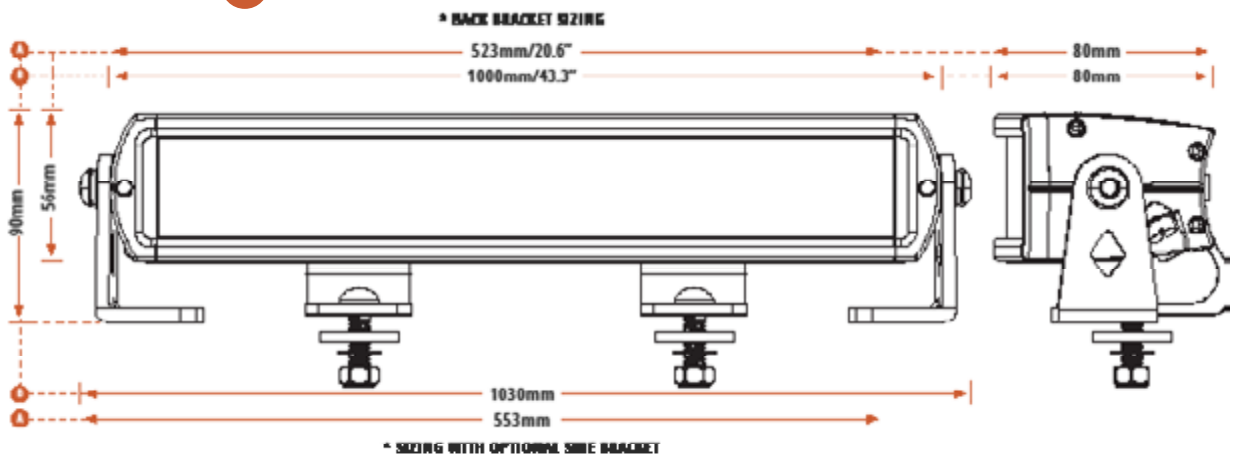

# SABRE SERIES

SABRE CURVED LIGHT BAR RANGE



**SPECIFICATIONS**

<b>SPECIFICATIONS</b>	<b>WATTAGE</b>	100 WATT
	<b>LIGHT SOURCE</b>	10 × 10W ETI LEDS
	<b>LIGHT OUTPUT</b>	9,500 LUMEN
	<b>VOLTAGE</b>	9V-36V DC
	<b>AMP DRAW</b>	6.5A/3.1A
	<b>OPERATING TEMP.</b>	-40°C TO +60°C
	<b>IP RATING</b>	IP68
	<b>CONNECTOR TYPE</b>	DEUTSCH CONNECTOR
	<b>HOUSING</b>	6063 EXTRUDED ALUMINUM HEAT-SINK
	<b>LENS CONSTRUCTION</b>	POLYCARBONATE
	<b>BRACKET</b>	STAINLESS STEEL
	<b>LIFESPAN</b>	50,000 HOURS
	<b>NET WEIGHT</b>	2.25 KG
	<b>MOUNTING SUITABLE</b>	UPRIGHT STANDARD SIDE/ SLIDEABLE
<b>WARRANTY</b>	3 YEARS	
<b>BEAM</b>	SPOT	
<b>CODES</b>	EVSC100LED	

**SLIMLINE 45W CURVED LIGHT BAR**



**SLIMLINE 60W CURVED LIGHT BAR**

<b>WATTAGE</b>	220 WATT
<b>LIGHT SOURCE</b>	22 × 10W ETI LEDS
<b>LIGHT OUTPUT</b>	20,900 LUMEN
<b>VOLTAGE</b>	9V-36V DC
<b>AMP DRAW</b>	14.2A/6.8A
<b>OPERATING TEMP.</b>	-40°C TO +60°C
<b>IP RATING</b>	IP68
<b>CONNECTOR TYPE</b>	DEUTSCH CONNECTOR
<b>HOUSING</b>	6063 EXTRUDED ALUMINUM HEAT-SINK
<b>LENS CONSTRUCTION</b>	POLYCARBONATE
<b>BRACKET</b>	STAINLESS STEEL
<b>LIFESPAN</b>	50,000 HOURS
<b>NET WEIGHT</b>	4.65 KG
<b>MOUNTING SUITABLE</b>	UPRIGHT STANDARD SIDE/ SLIDEABLE
<b>WARRANTY</b>	3 YEARS
<b>BEAM</b>	SPOT
<b>CODES</b>	EVSC220LED

